

SWITCH CIRCUIT			MATERIAL AND FINISH AS BELOW						
WHEN CARD IS EJECTED		WHEN CARD IS INSERTED		A	Housing	LCP UL94V-0, Color:Ivory	E		
				B	Contact	Brass C2680, Gold Plated Over Nickel	F		
				C	Holddown	Brass C2680, Tin Plated	G		
				D			H		

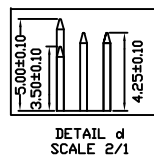
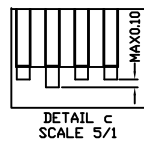
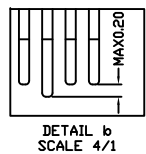
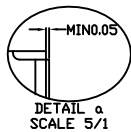
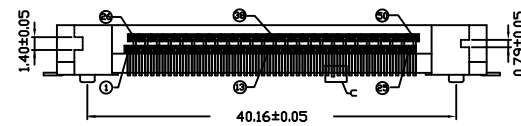
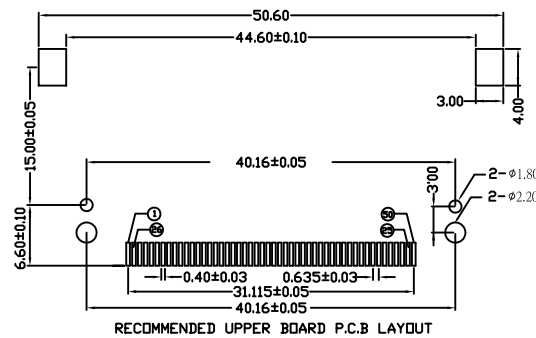
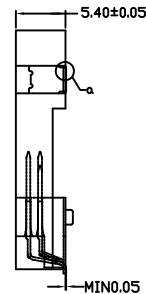
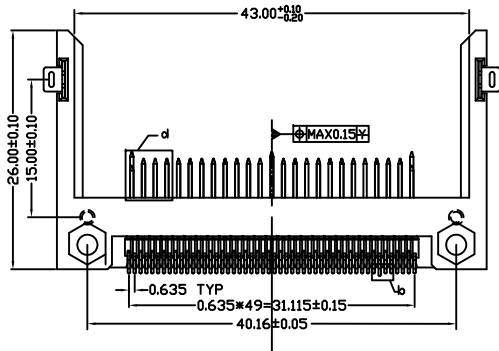
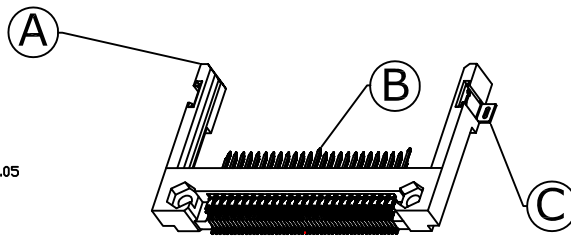
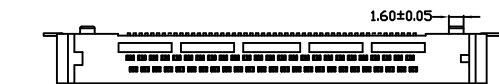

PIN NUMBER	DIML
25 26	3.50
ALL OTHER PINS	4.25
1 13 38 50	5.00

SPECIFICATION:

1. ELECTRICAL

- 1.1 Current Rating: 0.5AMP
- 1.2 Voltage Rating: 100VAC
- 1.3 Contact Resistance: 40mΩ
- 1.4 Insulation Resistance: 1000MΩ
- 1.5 Dielectric Withstanding Voltage: 500VAC for 1 minute

2. MECHANICAL

- 2.1 Durability: 10000Cycle
- 2.2 Insertion Force: 28.8N
- 2.3 Extraction Force: 4.9N

3. ENVIRONMENTAL

- 3.1 Operating temperature range: -40°C to +85°
- 3.2 Storage temperature range: -40°C to +85°

4. SOLDER ABILITY

- 4.1 Recommended IR Reflow Temperature: 260°C 10Sec

P1	P2	P3	P4	P5	P6	P7	P8	P9	P10	P11	P12
----	----	----	----	----	----	----	----	----	-----	-----	-----

PIN ASSIGNMENT

101D-RACA-R01 CF Socket Slim Type Peg:40.16, S/O:1.4mm, Contact Area:Gold Flash

PRODUCT NO. DESCRIPTION

UNLESS OTHERWISE SPECIFIED TOLERANCE		
ANGLES	ANG.	±5°
LINEAR	0.	±0.3
	0.0	±0.25
	0.00	±0.20
SCALE	AS SHOWN	UNIT: mm
DRAWN	Willis	2012/12/27
CHECKED	Angel	2012/12/27
APPROVED	Ken	2012/12/27



www.attend.com.tw

DRAWN NAME: CF Slim Socket Reverse Type Locating Peg:40.16,Stand off1.4mm

PRODUCT NO. 101D-RACA-R01

△	Revise:										
△	Revise:										
△	Revise:										

REV.	DESCRIPTION	DATE	REV.	DESCRIPTION	DATE	SIZE	REV.	FILE NAME
1			4			A4	1.0	101D-RACA-R01_B_1