

REV.	DESCRIPTION	DRAWN	DATE
0	PRELIMINARY	TIM	2016/07/28
1	INITIAL RELEASE	TIM	2016/09/23
2	CORRECTED	TIM	2016/11/04

NOTE:
DATE CODE: 6181 (YWWD)
Y : YEAR(2016)
WW: WEEK (01 ~ 52)
D : DAY (1 ~ 7)

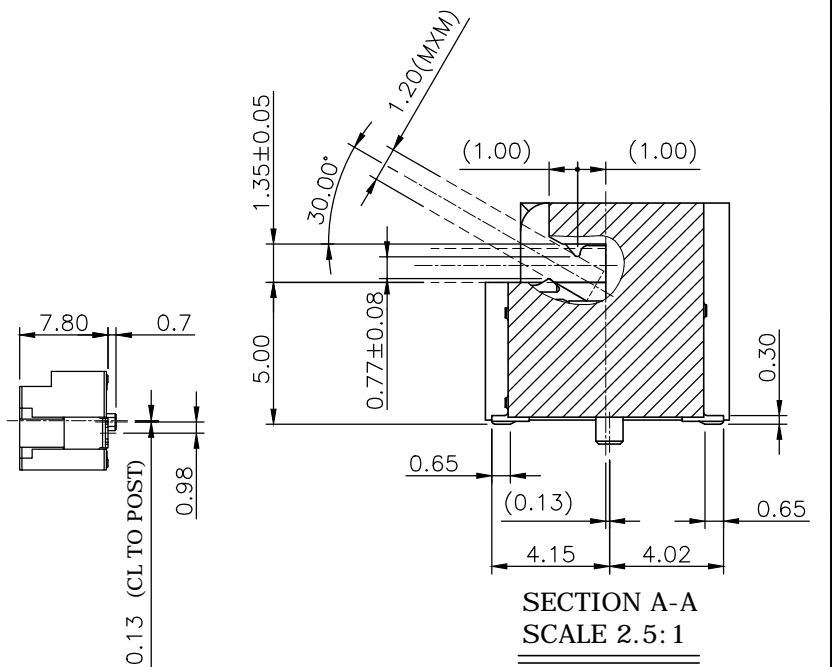
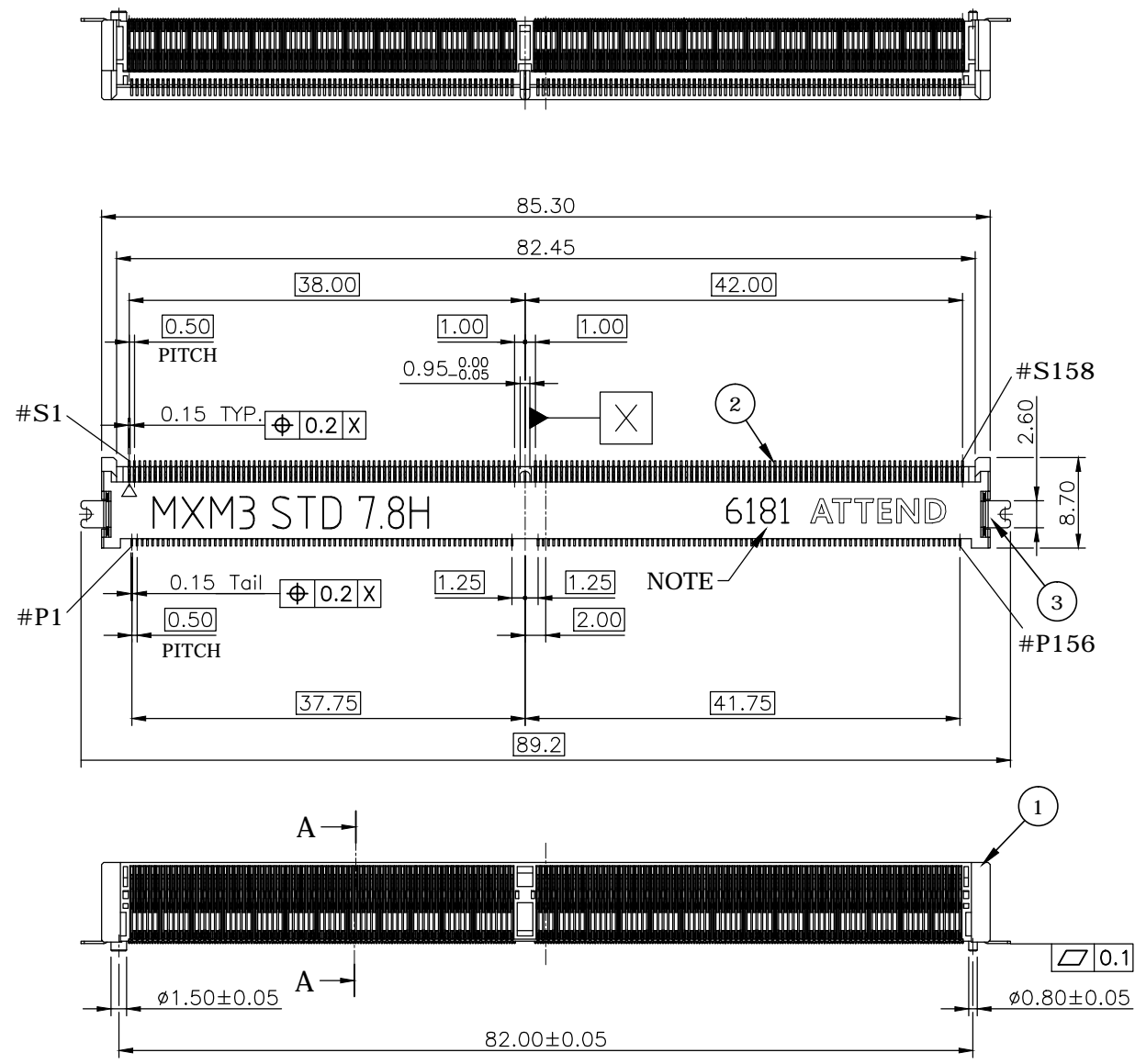

3	SOLDERPEG	Copper Alloy,Matte TIN 80μ"MIN. Ni Under Plated 60μ"MIN.
2	CONTACT	Copper Alloy,Contact:Au Plated 5μ"MIN. Ni Under Plated 60μ"MIN.
1	HOUSING	LCP, UL94V-0, Black
NO.	PART NAME	DESCRIPTION

UNLESS OTHERWISE SPECIFIED TOLERANCE			
UNIT:	DECIMAL	LINEAR	ANGLES
mm	X.	±0.50	±5°
	X.X	±0.25	±3°
	X.XX	±0.12	±1°



DRAWN	TIM	2016/07/28	DRAWN NAME:	MXM 3.0 314 pin for SMARC	
CHECKED	FROS	2016/07/28		0.5 Pitch, 7.8H, Standard Type, Reel	
APPROVED	Ken	2016/07/28	PRODUCT NO.	125B-78C00	
SCALE	1.5/1	SHEET	1/4	SIZE	A4
			FILE NAME	125B-78C00_B_2	

REV.	DESCRIPTION	DRAWN	DATE
	SEE SHEET ONE		

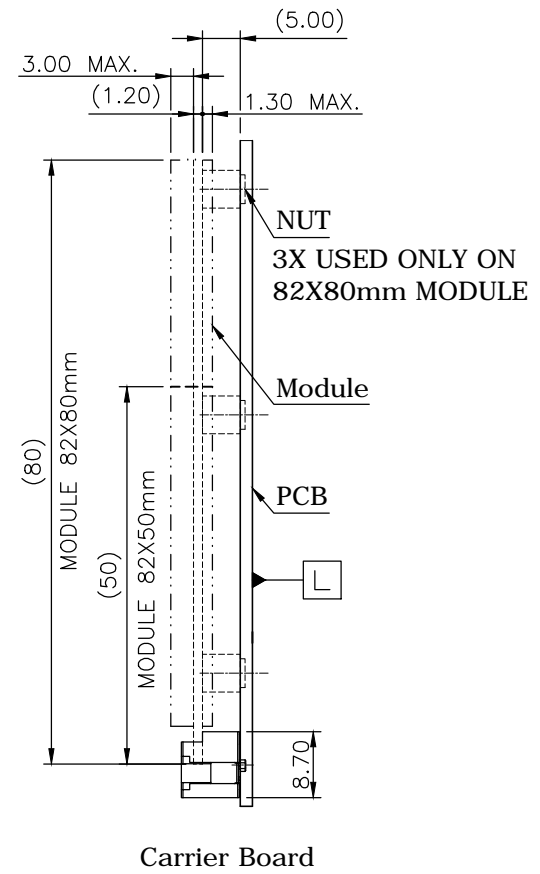
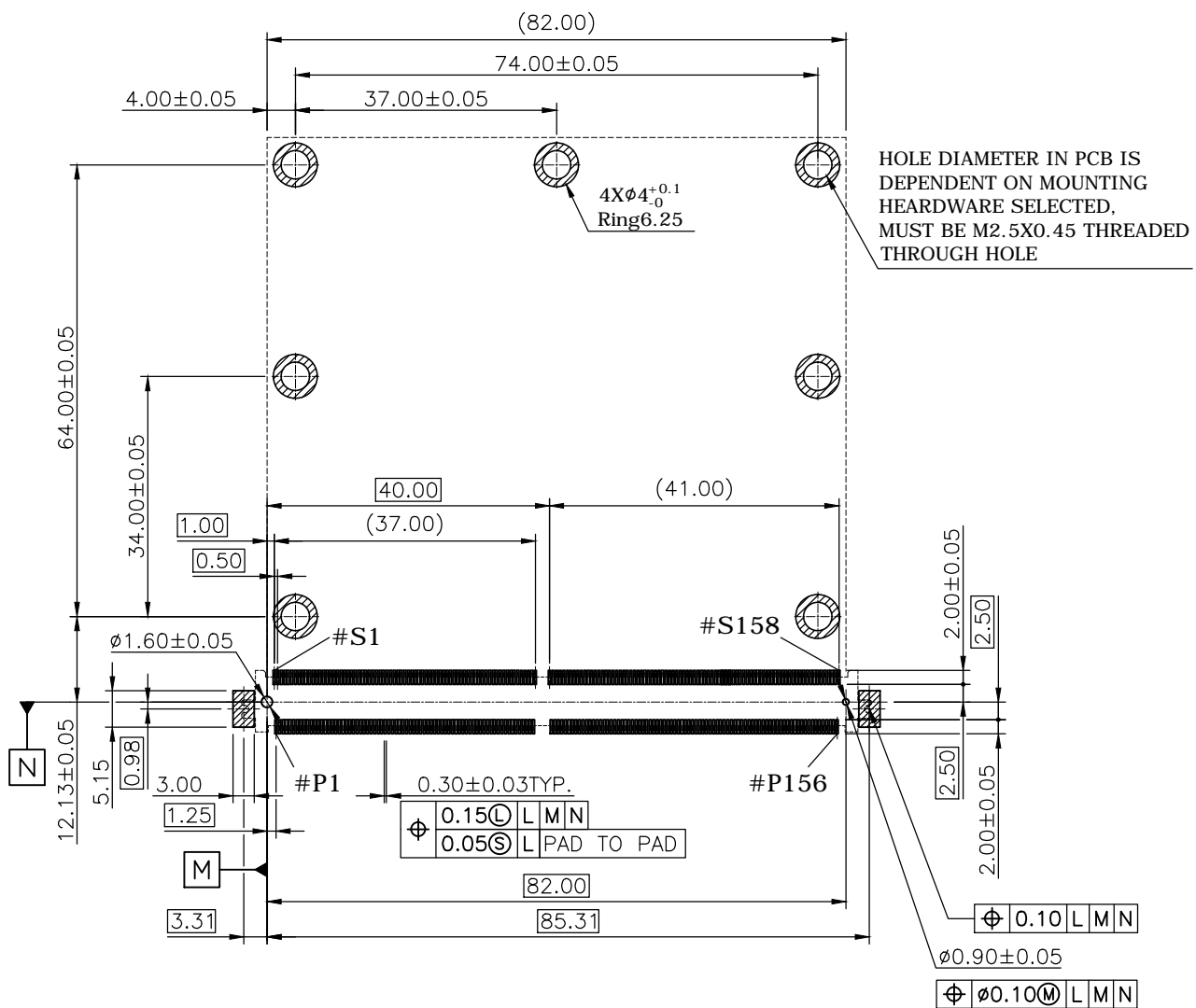

UNLESS OTHERWISE SPECIFIED TOLERANCE				 WWW.ATTEND.COM.TW		
UNIT:	DECIMAL	LINEAR	ANGLES			
mm	X.	±0.50	±5°			
	X.X	±0.25	±3°			
	X.XX	±0.12	±1°			
DRAWN	TIM	2016/07/28	DRAWN NAME:			
CHECKED	FROS	2016/07/28	MXM 3.0 314 pin for SMARC			
APPROVED	Ken	2016/07/28	0.5 Pitch, 7.8H, Standard Type, Reel			
SCALE	SHEET	SIZE	PRODUCT NO.	125B-78C00		
1/1	2/4	A4	FILE NAME	125B-78C00_B_2		

REV.	DESCRIPTION	DRAWN	DATE
	SEE SHEET ONE		

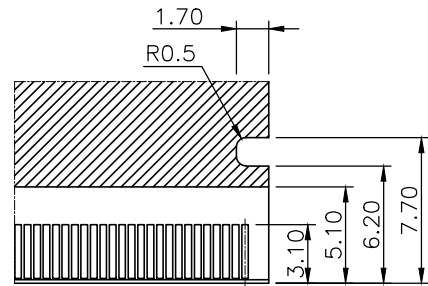

DETAIL A
SCALE 2.5:1

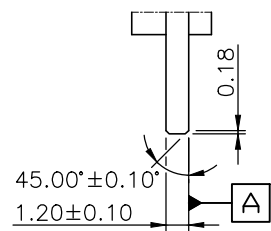

DETAIL B
SCALE 2.5:1

NOTES; (APPLIED TO SHEET 3)

- 1.TOLERANCES ON ALL DIMENSION ± 0.1 UNLESS OTHERWISE SPECIFIED.
- 2.P.C.BOARD THICKNESS APPLIES ACROSS TABS AND INCLUDES PLATING AND/OR METALIZATION.
- 3.FINISH OF PAD : GOLD PLATING 30μ "MIN. OVER Ni PLATING 80μ "MIN.
- 4.The common dimension for MXM3.0-TYPE A,B when there is no special mention.

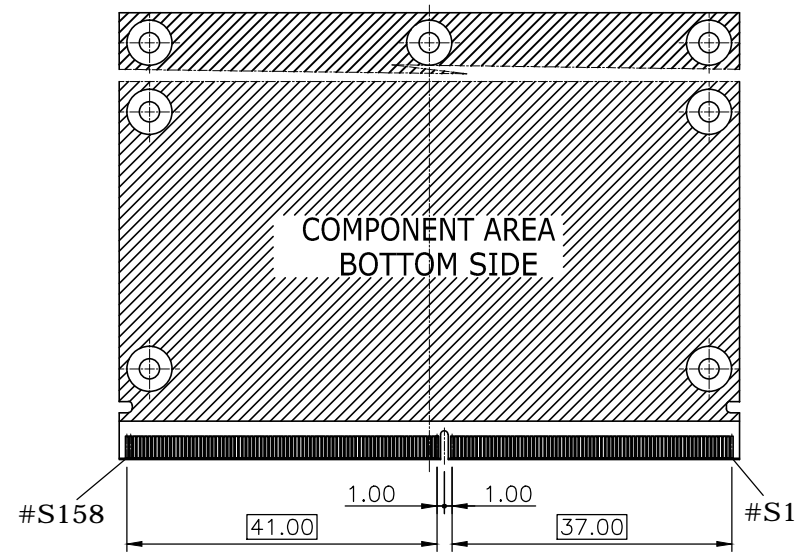
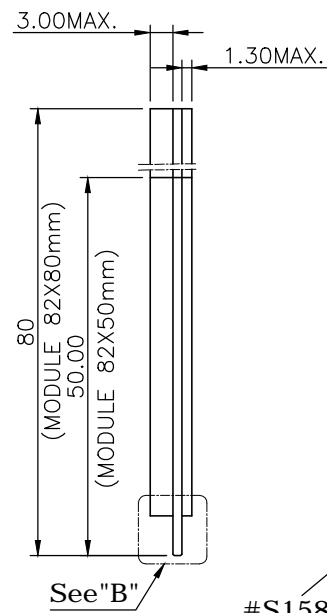
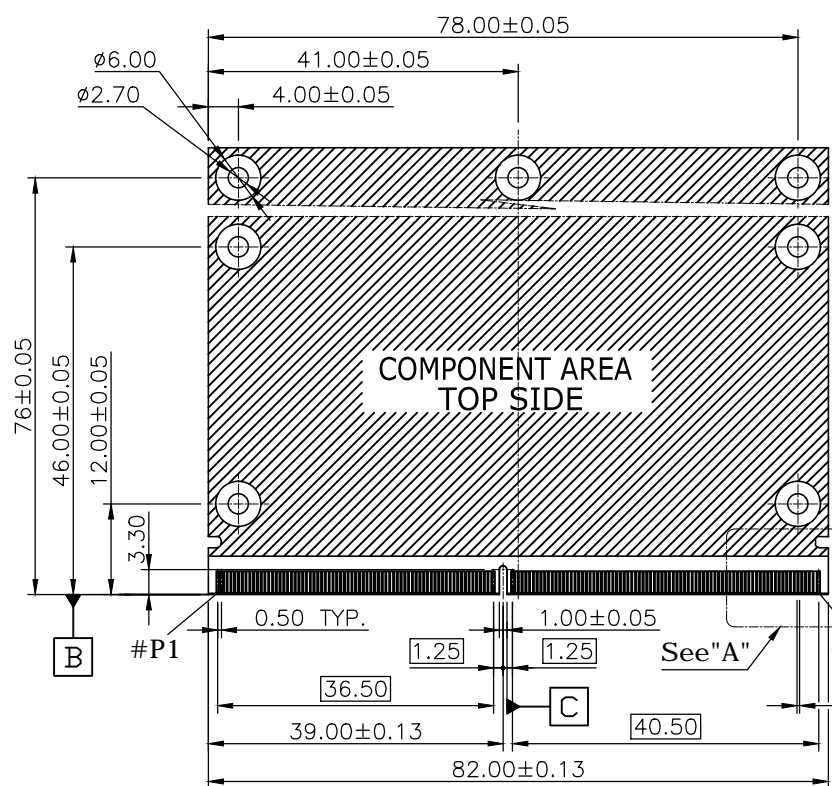

ϕ	0.15(L)	A	B	C
ϕ	0.05(S)	A	PAD TO PAD	

UNLESS OTHERWISE SPECIFIED TOLERANCE			
UNIT:	DECIMAL	LINEAR	ANGLES
mm	X.	± 0.50	$\pm 5^\circ$
	X.X	± 0.25	$\pm 3^\circ$
	X.XX	± 0.12	$\pm 1^\circ$



DRAWN	TIM	2016/07/28	DRAWN NAME:	WWW.ATTEND.COM.TW	
CHECKED	FROS	2016/07/28	MXM 3.0 314 pin for SMARC		
APPROVED	Ken	2016/07/28	0.5 Pitch, 7.8H, Standard Type, Reel		
SCALE	1/1	SHEET	3/4	SIZE	A4
PRODUCT NO.	125B-78C00		FILE NAME	125B-78C00_B_2	

REV.	DESCRIPTION	DRAWN	DATE
	SEE SHEET ONE		

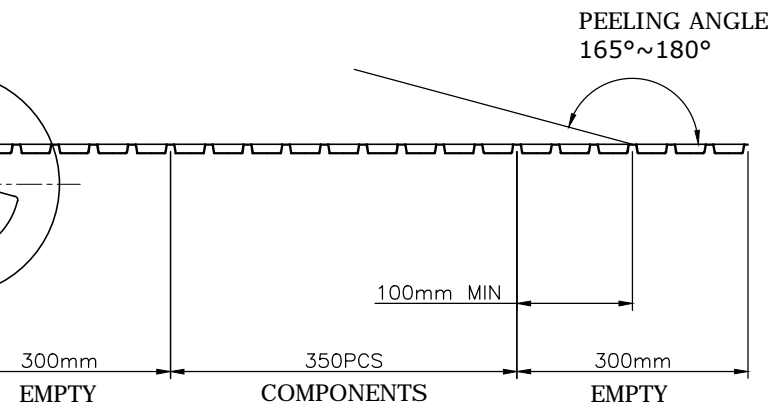
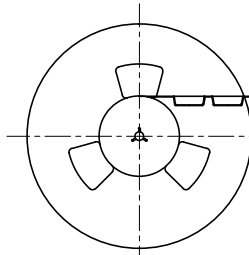
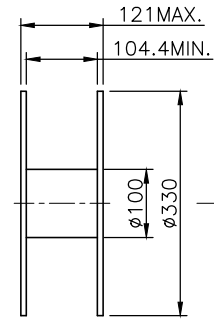
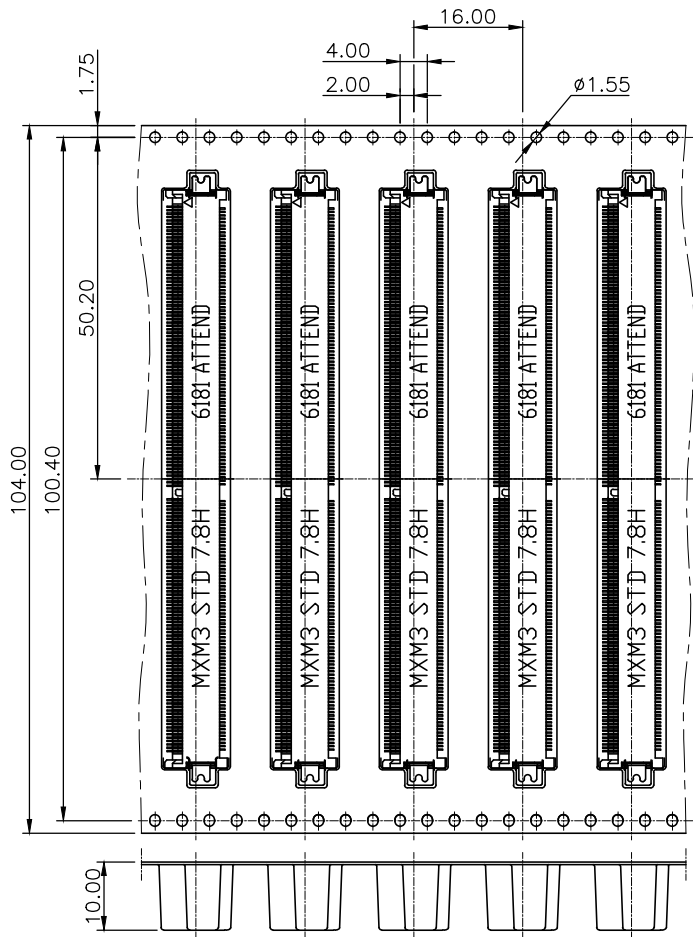

PULL OUT DIRECTION →

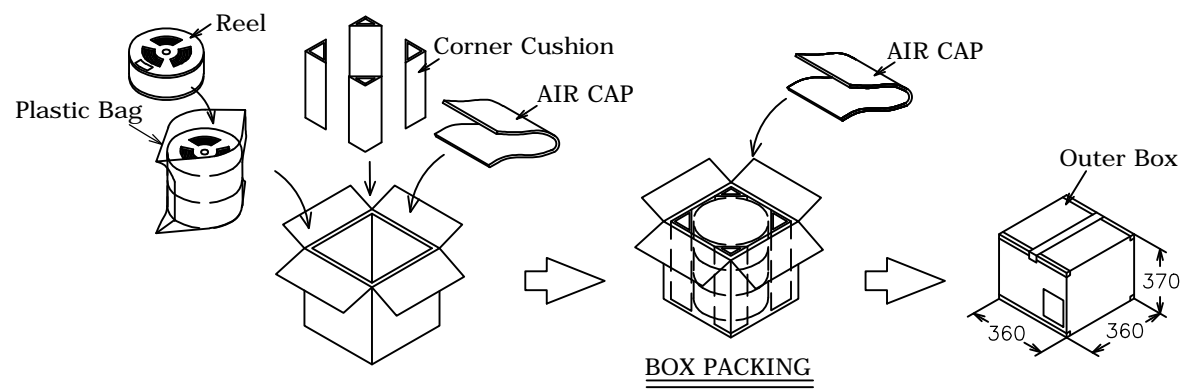

PACKAGING SPECIFICATION:

- 1. PACKING
- 1.1 Quantity:
 - 350 Piece/ Reel
 - 1050 Piece/ Carton

UNLESS OTHERWISE SPECIFIED TOLERANCE

UNIT:	DECIMAL	LINEAR	ANGLES
mm	X.	±0.50	±5°
	X.X	±0.25	±3°
	X.XX	±0.12	±1°



WWW.ATTEND.COM.TW

DRAWN	TIM	2016/07/28	DRAWN NAME:
CHECKED	FROS	2016/07/28	MXM 3.0 314 pin for SMARC
APPROVED	Ken	2016/07/28	0.5 Pitch, 7.8H, Standard Type, Reel
SCALE	N/A	SHEET 4/4	SIZE A4
FILE NAME	125B-78C00_B_2		