

REV.	DESCRIPTION	DRAWN	DATE
1	INITIAL RELEASE	TIM	2020/06/10

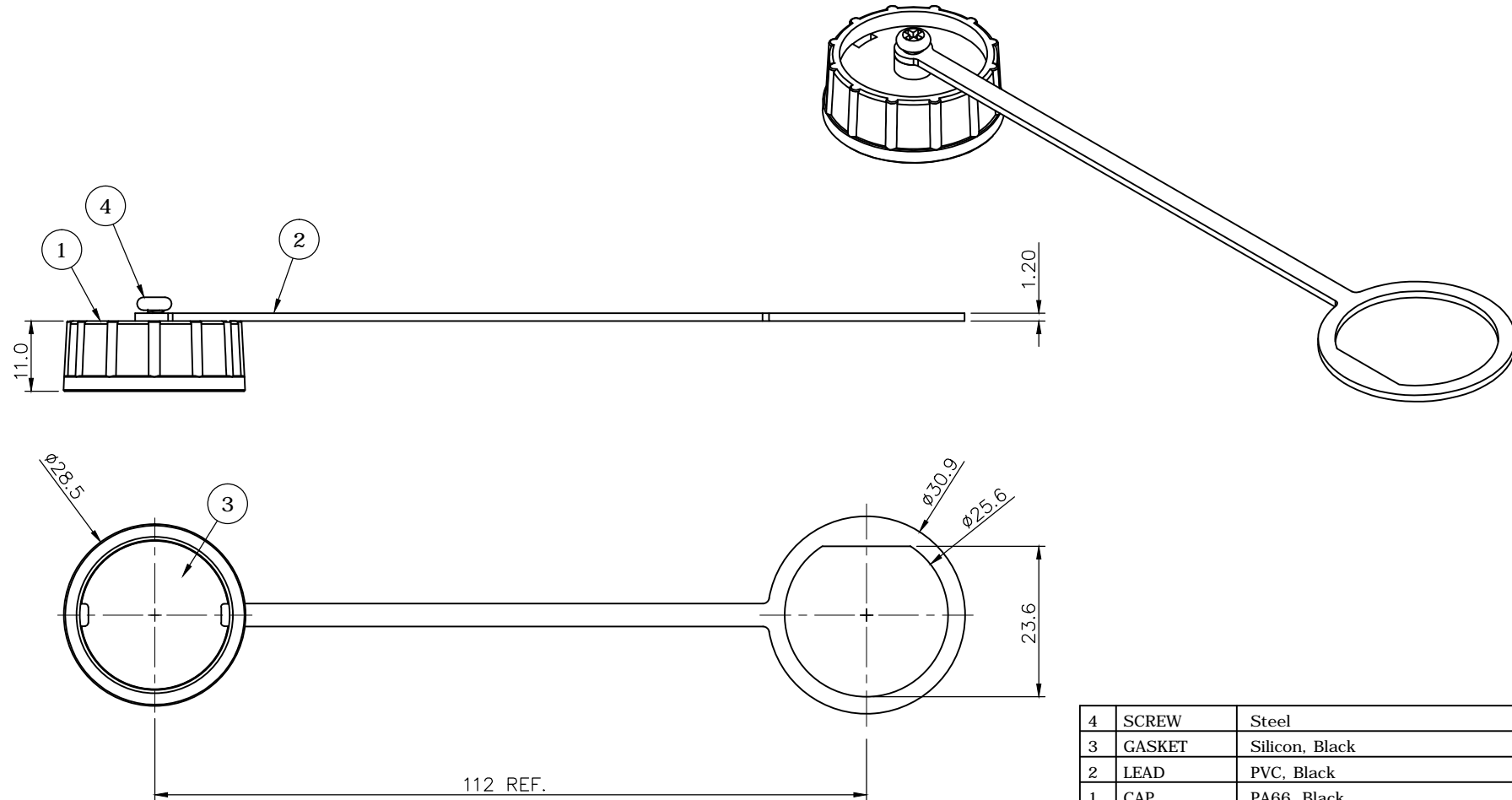

4	SCREW	Steel						
3	GASKET	Silicon, Black						
2	LEAD	PVC, Black						
1	CAP	PA66, Black						
NO.	PART NAME	DESCRIPTION						
UNLESS OTHERWISE SPECIFIED TOLERANCE								
UNIT:	DECIMAL	LINEAR	ANGLES					
mm	X.	±0.50	±5°					
	X.X	±0.25	±3°					
	X.XX	±0.12	±1°					
DRAWN		Tim	2020/06/10	DRAWN NAME: D Size Waterproof Cover Lock Bayonet Type				
CHECKED		Fros	2020/06/10					
APPROVED		Ken	2020/06/10					
SCALE		1/1	SHEET	1/1	SIZE	A4	PRODUCT NO.	227D-0001
FILE NAME		227D-0001_B_1						



www.attend.com.tw