

REV.	DESCRIPTION	DRAWN	DATE
2	ECR230609001	Wen	2023/06/09
3	ECR2400005	Fros	2024/09/13
4	ECR260506001	Fros	2026/05/06

SPECIFICATION:

1. ELECTRICAL

- 1.1 Current Rating: 5A MAX.
- 1.2 Voltage Rating: 20V DC
- 1.3 Contact Resistance: 40mΩ
- 1.4 Insulation Resistance: 100MΩ
- 1.5 Dielectric Withstanding Voltage: 100VAC

2. MECHANICAL

- 2.1 Durability: 10,000 Cycle
- 2.2 Insertion Force: 5N to 20N
- 2.3 Extraction Force: 8N to 20N

3. ENVIRONMENTAL

- 3.1 Operating temperature range: -40°C~+85°C

4. SOLDER ABILITY

- 4.1 Recommended IR Reflow(Wave Soldering) Temperature: 260°C

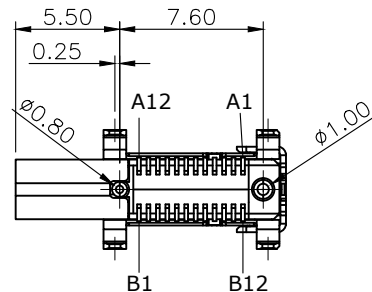
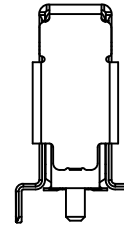
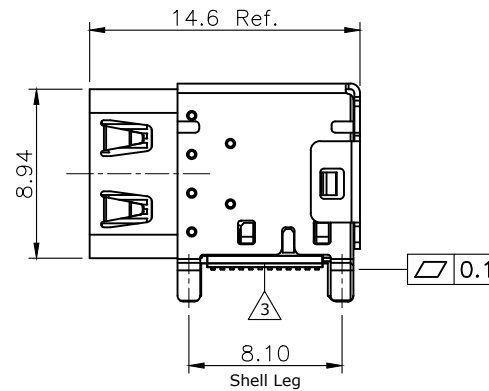
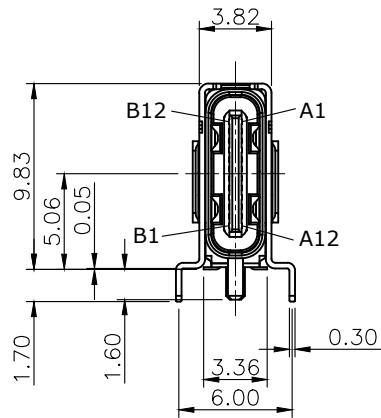
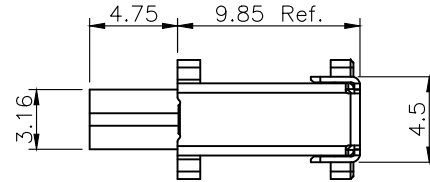
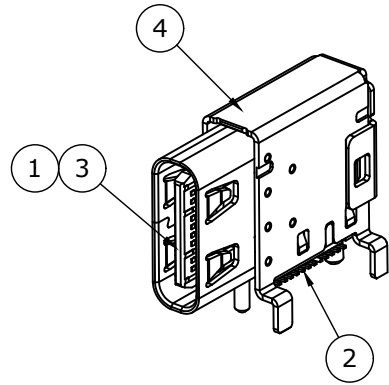

4	SHELL	Stainless steel, nickel plating
3	MID PLATE	Stainless steel
2	CONTACT	Copper alloy, Gold plating on contact area, G/F on solder area, Nickel under plating
1	INSULATOR	LCP, UL94V-0, Black

NO.		PART NAME	DESCRIPTION
UNLESS OTHERWISE SPECIFIED TOLERANCE			
UNIT:	DECIMAL	LINEAR	ANGLES
	mm	X. ±0.50	±5°
		X.X ±0.25	±3°
		X.XX ±0.12	±1°
DRAWN		Fros	2020/11/10
CHECKED		Tim	2020/11/10
APPROVED		Ken	2020/11/10
SCALE		2.5	SHEET 1/2
SIZE		A4	
DRAWN NAME:		USB Type C Flank Receptacle T/H w/SMD type, G/F Reel	
PRODUCT NO.		217E-BA01	
FILE NAME		217E-BA01_B_4	



www.attend.com.tw

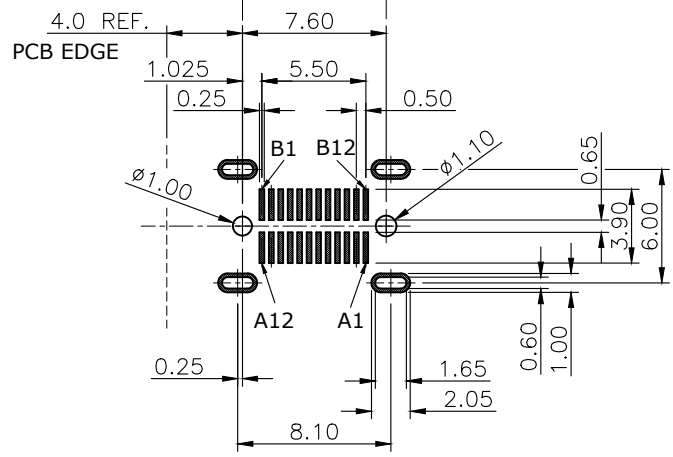
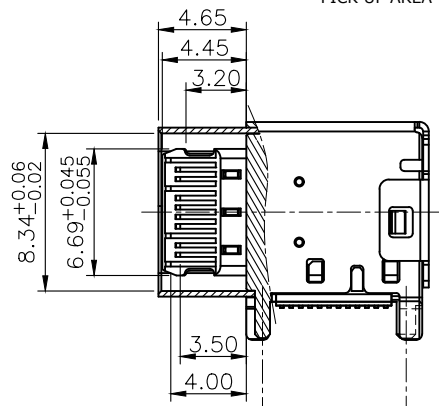
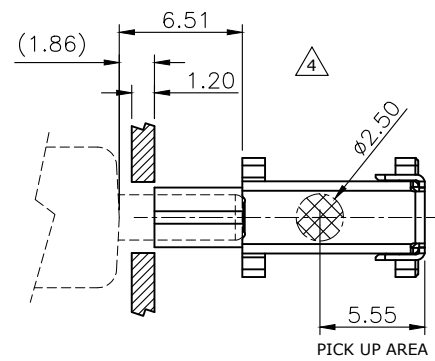

RECOMMEND LAYOUT (TOP VIEW)
GENERAL TOLERANCE: ± 0.05

REV.	DESCRIPTION	DRAWN	DATE
------	-------------	-------	------

PIN ASSIGNMENTS:

PIN NUMBER	SIGNAL NAME	PIN NUMBER	SIGNAL NAME
A1	GND	B12	GND
A2	SSTXp1	B11	SSRXp1
A3	SSTXn1	B10	SSRXn1
A4	VBUS	B9	VBUS
A5	CC1	B8	SBU2
A6	Dp1	B7	Dn2
A7	Dn1	B6	Dp2
A8	SBU1	B5	CC2
A9	VBUS	B4	VBUS
A10	SSRXn2	B3	SSTXn2
A11	SSRXp2	B2	SSTXp2
A12	GND	B1	GND

UNLESS OTHERWISE SPECIFIED TOLERANCE

UNIT:	DECIMAL	LINEAR	ANGLES
mm	X.	± 0.50	$\pm 5^\circ$
	X.X	± 0.25	$\pm 3^\circ$
	X.XX	± 0.12	$\pm 1^\circ$



www.attend.com.tw

DRAWN	Fros	2020/11/10	DRAWN NAME:		
CHECKED	Tim	2020/11/10	USB Type C Flank Receptacle T/H w/SMD type, G/F Reel		
APPROVED	Ken	2020/11/10	PRODUCT NO.	217E-BA01	
SCALE	2.5	SHEET	2/2	SIZE	A4
FILE NAME	217E-BA01_B_4				

REV.	DESCRIPTION	DRAWN	DATE
1	INITIAL RELEASE	FROS	2020/11/10

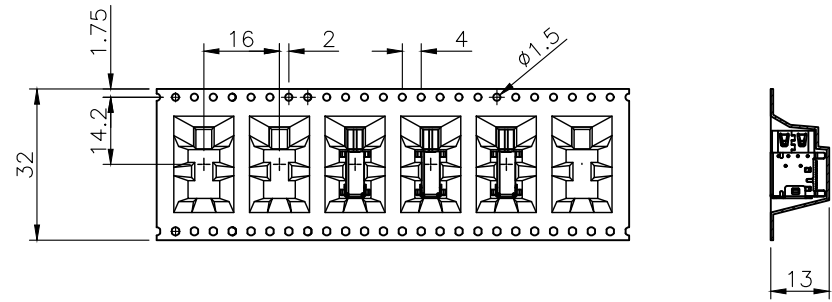
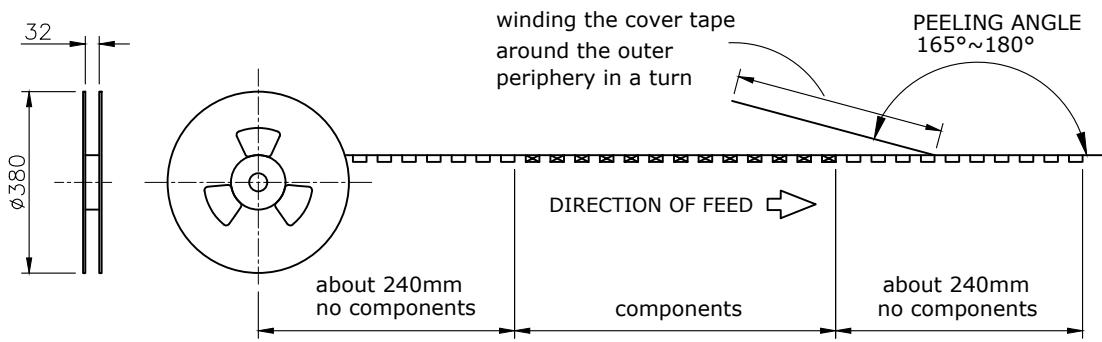

PACKAGING SPECIFICATION:

1. MATERIAL
 - 1.1 Embossed Carrier Tape: PET, Transparent
 - 1.2 Top Cover Tape: PE
20-80g(Peel Speed 300mm/Minute)
 - 1.3 Taping Reel: Plastic
2. PACKING
 - 2.1 Quantity:
450 Piece/Reel
8 Reel/PE Bag
3600 Piece/Carton

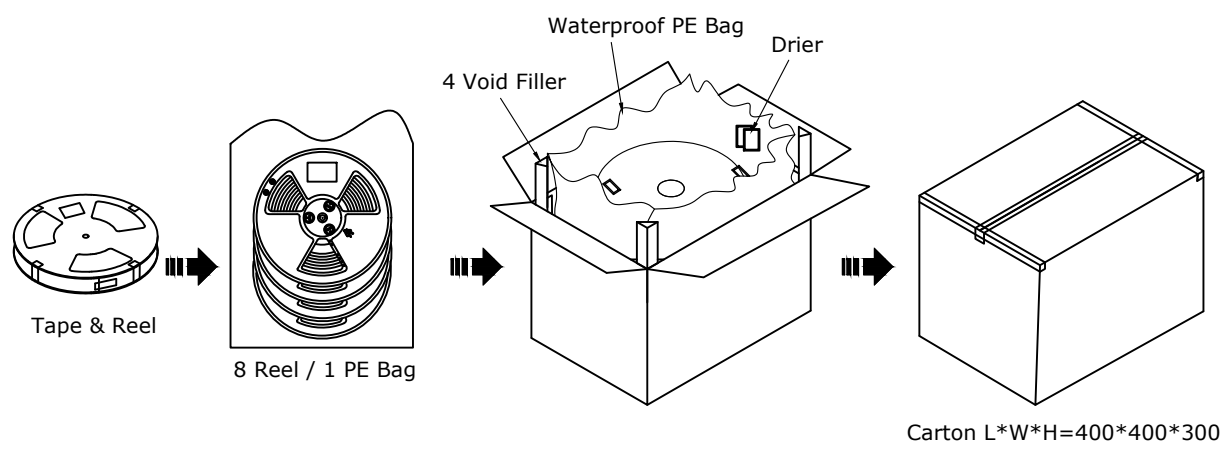

UNLESS OTHERWISE SPECIFIED TOLERANCE

UNIT:	DECIMAL	LINEAR	ANGLES
mm	X.	±0.50	±5°
	X.X	±0.25	±3°
	X.XX	±0.12	±1°



www.attend.com.tw

DRAWN	Fros	2020/11/10	DRAWN NAME: USB Type C Flank Receptacle T/H w/SMD type, G/F Reel				
CHECKED	Tim	2020/11/10					
APPROVED	Ken	2020/11/10					
SCALE	0.625	SHEET	1/1	SIZE	A4	PRODUCT NO.	217E-BA01
						FILE NAME	217E-BA01_D_1