

REV.	DESCRIPTION	DRAWN	DATE
1	INITIAL RELEASE	FROS	2024/09/05

SPECIFICATION:

1. ELECTRICAL
 - 1.1 Current Rating: 1A (power pin)
 - 1.2 Voltage Rating: 50VAC
 - 1.3 Contact Resistance: 55mΩ, Δ20mΩ MAX.
 - 1.4 Insulation Resistance: 500MΩ
 - 1.5 Dielectric Withstanding Voltage: 300VAC
2. MECHANICAL
 - 2.1 Durability: 60 Cycle
 - 2.2 Mating Force: 25N max.
 - 2.3 Un-mating Force: 25N max.
3. ENVIRONMENTAL
 - 3.1 Operating temperature range: -40°C~+85°C
 - 3.2 Storage temperature range: -40°C~+85°C
4. SOLDER ABILITY
 - 4.1 Recommended IR-Reflow Temperature: 260°C

6	CAP	Thermoplastic, UL94V-0, black
5	SHIELD	Copper alloy, 50u" min. nickel plating over all
4	HOLD DOWN	Copper alloy, 50u" min. matte tin plating 50u" min. under-plating Nickel
3	LOWER CONTACT	Copper alloy, contact area: gold flash, solder area: gold flash, under-plating
2	UPPER CONTACT	50u" min. nickel over all
1	INSULATOR	Thermoplastic, UL94V-0, black
NO.	PART NAME	DESCRIPTION

UNLESS OTHERWISE SPECIFIED TOLERANCE

UNIT:	DECIMAL	LINEAR	ANGLES
mm	X.	±0.50	±5°
	X.X	±0.25	±3°
	X.XX	±0.12	±1°



www.attend.com.tw

DRAWN	Fros	2024/09/05	DRAWN NAME:	M.2 Gen5 Socket, H8.5 E Key	
CHECKED	Tim	2024/09/05		0.5 Pitch G/F, Black, Reel	
APPROVED	Ken	2024/09/05	PRODUCT NO.	123A-85E02	
SCALE	3.2/1	SHEET	1/4	SIZE	A4
		FILE NAME	123A-85E02_B_1		

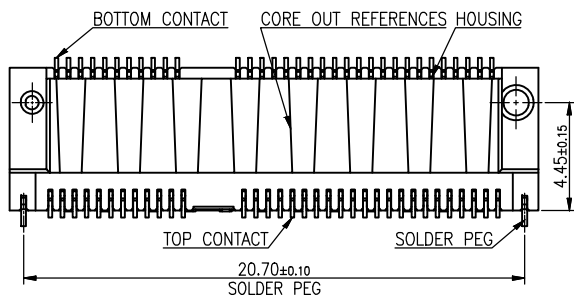
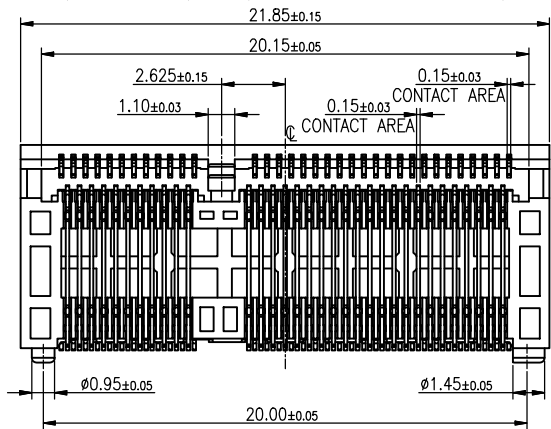
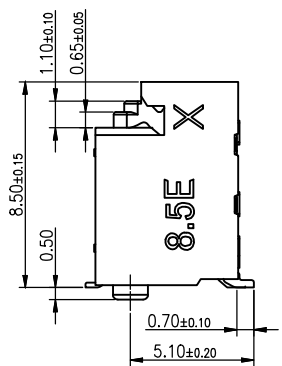
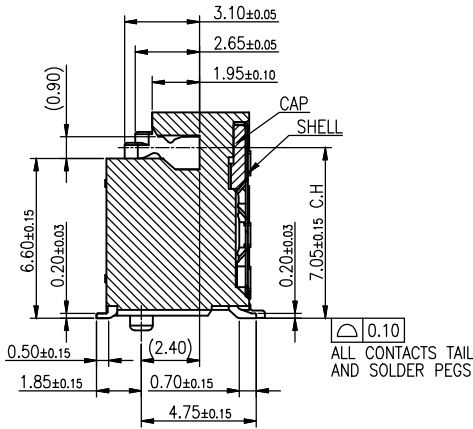
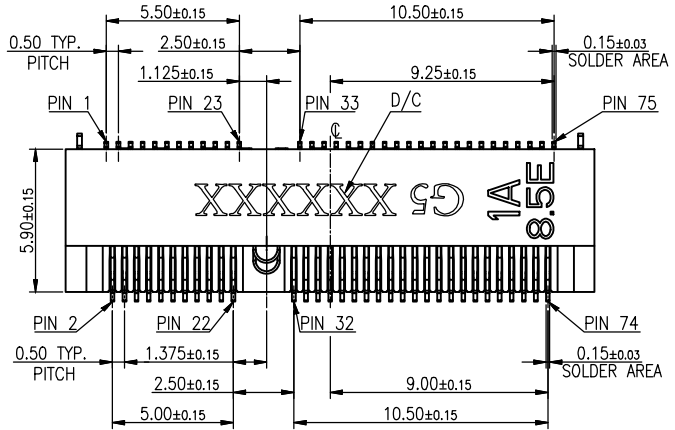

REV.	DESCRIPTION	DRAWN	DATE

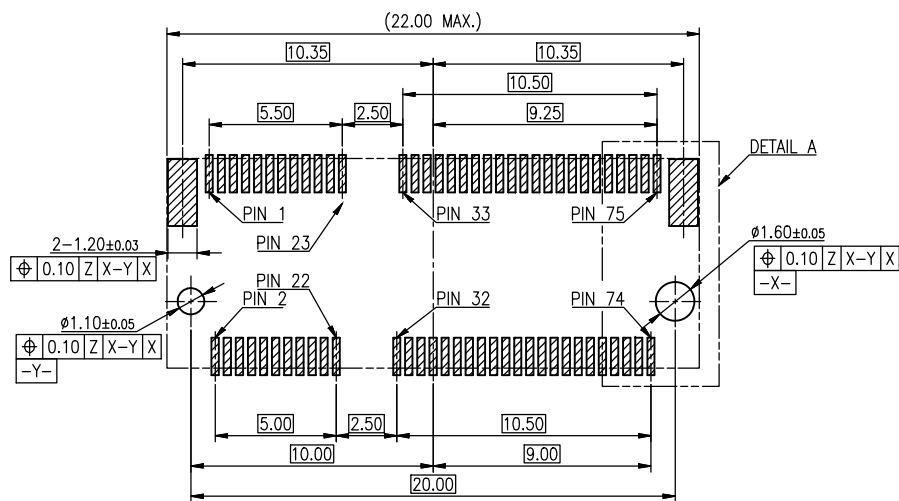

RECOMMEND PCB LAYOUT(TOP VIEW)
(DEFAULT TOLERANCE:±0.05mm)

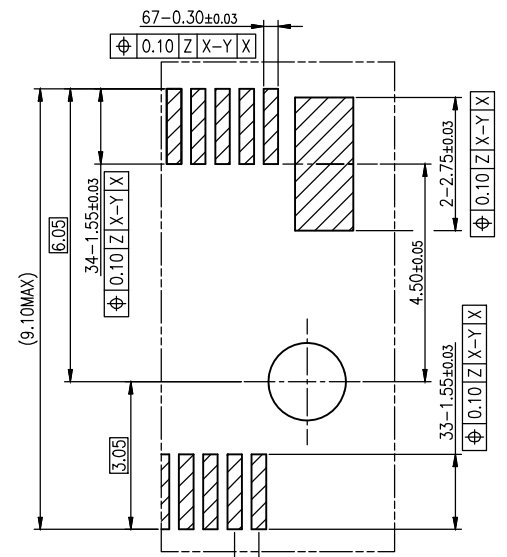

DETAIL A
SCALE 2:1

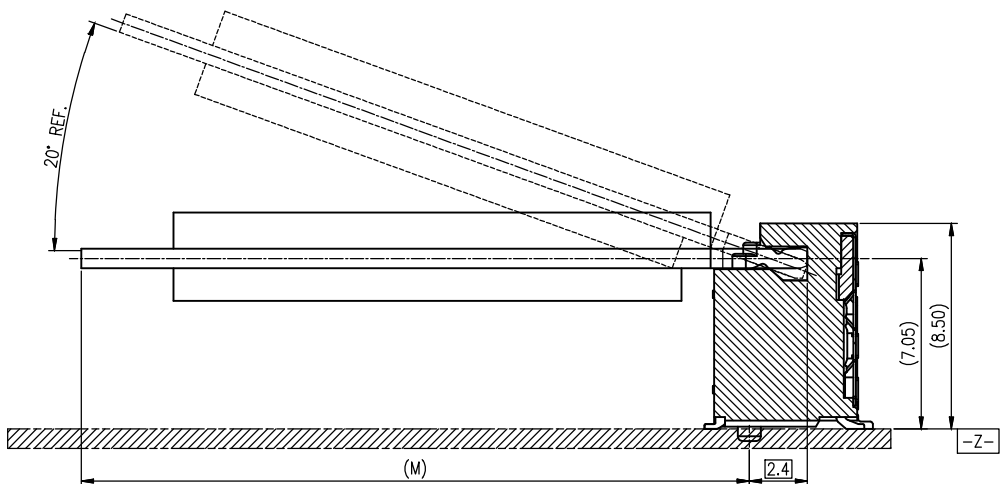

MODULE SEATING PLANT
TO ALIGNMENT POST

30.00	(108.25)
	(78.25)
22.00	(40.25)
	(28.25)
DIM. K	DIM. M

UNLESS OTHERWISE SPECIFIED TOLERANCE				
UNIT:	DECIMAL	LINEAR	ANGLES	
mm	X.	±0.50	±5°	
	X.X	±0.25	±3°	
	X.XX	±0.12	±1°	
DRAWN	Fros	2024/09/05	DRAWN NAME: M.2 Gen5 Socket, H8.5 E Key 0.5 Pitch G/F, Black, Reel	
CHECKED	Tim	2024/09/05		
APPROVED	Ken	2024/09/05	PRODUCT NO. 123A-85E02	
SCALE	N/A	SHEET 2/4	SIZE A4	FILE NAME 123A-85E02_B_1



www.attend.com.tw

REV.	DESCRIPTION	DRAWN	DATE
------	-------------	-------	------

Table: Connector Pinout Definitions(Key E)

PIN	SIGNAL	SIGNAL	PIN
74	3.3V	GND	75
72	3.3V	RESERVED/REFCLKn1	73
70	UIM_POWER_SRC/GPIO_1/PEWAKE1#	RESERVED/REFCLKp1	71
68	UIM_POWER_SNK/CLKREQ1#	GND	69
66	UIM_SWP/PERST1#	RESERVED/PERn1	67
64	VIO 1.8V	RESERVED/PERp1	65
62	ALERT#(I)(0/1.8V)	GND	63
60	I2C_CLK(O)(0/1.8V)	RESERVED/PETn1	61
58	I2C_DATA(I/O)(0/1.8V)	RESERVED/PETp1	59
56	W_DISABLE1#(O)(0/1.8V/3.3V)	GND	57
54	W_DISABLE2#(O)(0/1.8V/3.3V)	PEWAKE0#(I/O)(0/1.8V/3.3V)	55
52	PERSTO#(O)(0/1.8V/3.3V)	CLKREQ0#(I/O)(0/1.8V/3.3V)	53
50	SUSCLK(O)(0/1.8V/3.3V)	GND	51
48	COEX_TXD(O)(0/1.8V)	PEFCLKn0	49
46	COEX_RXD(I)(0/1.8V)	PEFCLKp0	47
44	COEX3(I/O)(0/1.8V)	GND	45
42	VENDOR DEFINED	PERn0	43
40	VENDOR DEFINED	PERp0	41
38	VENDOR DEFINED	GND	39
36	UART_RTS(O)(0/1.8V)	PETn0	37
34	UART_CTS(I)(0/1.8V)	PETp0	35
32	UART_TXD(O)(0/1.8V)	GND	33
	CONNECTOR KEY E	CONNECTOR KEY E	
22	UART_RXD(I)(0/1.8V)	SDIO_RESET#TX_BLANKING(O)(0/1.8V)	23
20	UART_WAKE#(I)(0/3.3V)	SDIO_WAKE#(I)(0/1.8V)	21
18	VIO_CFG(I)	SDIO_DATA3#(I/O)(0/1.8V)	19
16	LED_2#(I)(OD)	SDIO_DATA2#(I/O)(0/1.8V)	17
14	PCM_OUT/I2S_SD_OUT(O)(0/1.8V)	SDIO_DATA1#(I/O)(0/1.8V)	15
12	PCM_IN/I2S_SD_IN(I)(0/1.8V)	SDIO_DATA0#(I/O)(0/1.8V)	13
10	PCM_SYNC/I2S_WS(I/O)(0/1.8V)	SDIO_CMD(I/O)(0/1.8V)	11
08	PCM_CLK/I2S_SCK(I/O)(0/1.8V)	SDIO_CLK/SYSCLK(O)(0/1.8V)	09
06	LED_1#(I)(OD)	GND	07
04	3.3V	USB_D-	05
02	3.3V	USB_D+	03
		GND	01

SHELL
GND

SHELL
GND

UNLESS OTHERWISE SPECIFIED TOLERANCE				
UNIT:	DECIMAL	LINEAR	ANGLES	
mm	X.	±0.50	±5°	
	X.X	±0.25	±3°	
	X.XX	±0.12	±1°	
DRAWN	Fros	2024/09/05	DRAWN NAME: M.2 Gen5 Socket, H8.5 E Key 0.5 Pitch G/F, Black, Reel	
CHECKED	Tim	2024/09/05		
APPROVED	Ken	2024/09/05	PRODUCT NO. 123A-85E02	
	SCALE N/A	SHEET 3/4	SIZE A4	FILE NAME 123A-85E02_B_1



www.attend.com.tw

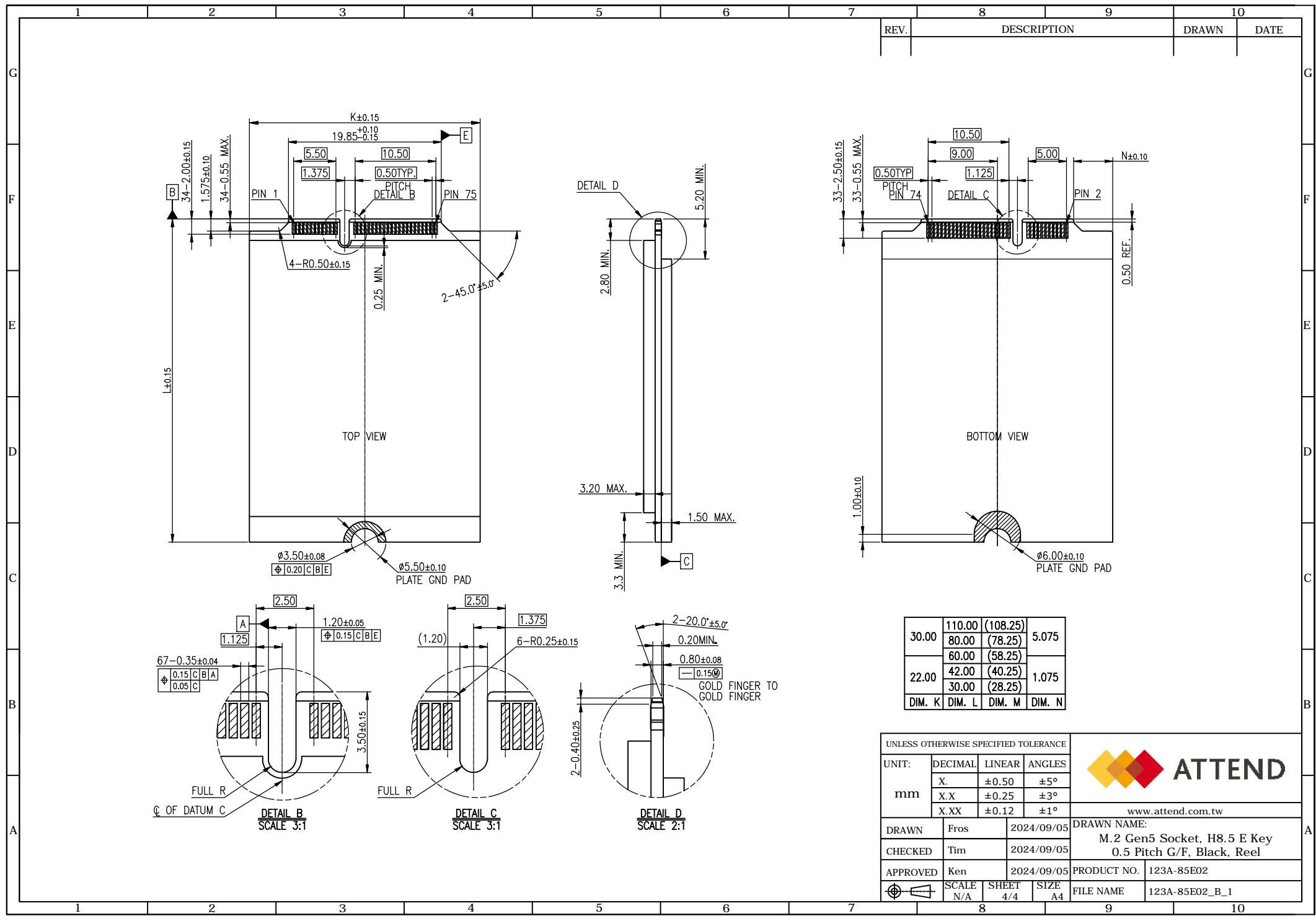

REV.	DESCRIPTION	DRAWN	DATE
------	-------------	-------	------

30.00	110.00 (108.25)	5.075	
	80.00 (78.25)		
22.00	60.00 (58.25)	1.075	
	42.00 (40.25)		
	30.00 (28.25)		
DIM. K	DIM. L	DIM. M	DIM. N

UNLESS OTHERWISE SPECIFIED TOLERANCE			
UNIT:	DECIMAL	LINEAR	ANGLES
mm	X.	± 0.50	$\pm 5^\circ$
	X.X	± 0.25	$\pm 3^\circ$
	X.XX	± 0.12	$\pm 1^\circ$



www.attend.com.tw

DRAWN	Fros	2024/09/05	DRAWN NAME:
CHECKED	Tim	2024/09/05	M.2 Gen5 Socket, H8.5 E Key 0.5 Pitch G/F, Black, Reel
APPROVED	Ken	2024/09/05	PRODUCT NO. 123A-85E02
SCALE	N/A	SHEET 4/4	SIZE A4
FILE NAME	123A-85E02_B_1		

REV.	DESCRIPTION	DRAWN	DATE
1	INITIAL RELEASE	FROS	2024/09/05

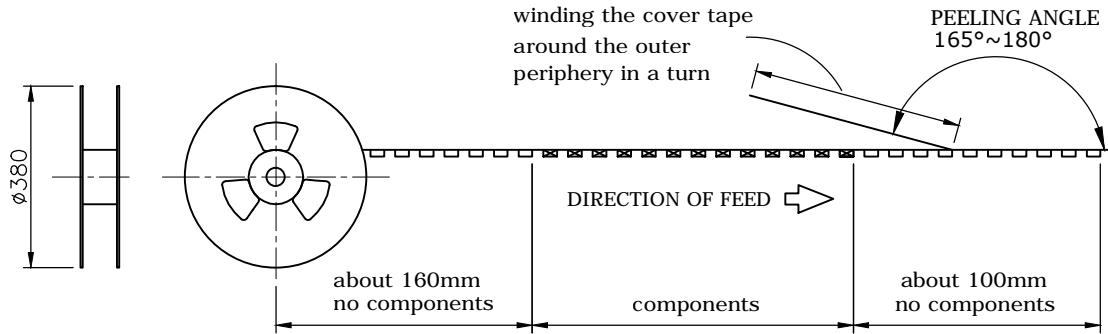

PACKAGING SPECIFICATION:

1. MATERIAL

- 1.1 Embossed Carrier Tape: PS Black
- 1.2 Top Cover Tape: PET 20-80g (Peel Speed 300mm/Minute)
- 1.3 Taping Reel: Plastic

2. PACKING

PART NO.	PCS/REEL	REEL/CARTON	PCS/ CARTON
123A-85B02	500	5	2500
123A-85E02			
123A-85M02			

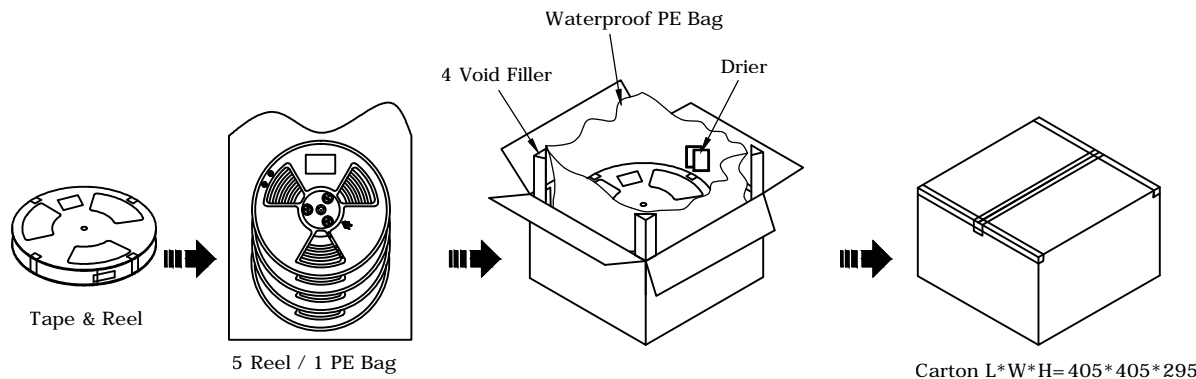
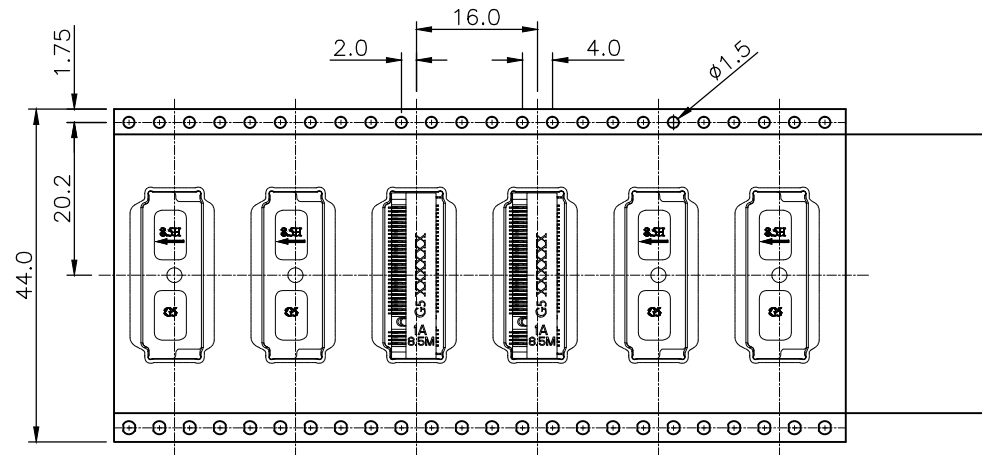

UNLESS OTHERWISE SPECIFIED TOLERANCE			
UNIT:	DECIMAL	LINEAR	ANGLES
mm	X.	±0.50	±5°
	X.X	±0.25	±3°
	X.XX	±0.12	±1°



www.attend.com.tw

DRAWN	Fros	2024/09/05	DRAWN NAME:	
CHECKED	Tim	2024/09/05	PACKING, M.2 Gen5 Socket, H8.5	
APPROVED	Ken	2024/09/05	PRODUCT NO.	
SCALE	1/1	SHEET	1/1	SIZE
				A4
FILE NAME			123A-85X02_D_1	